

ID-CC4-2A-SA

Strain gauge conditioner

511

- Strain gauges conditioners
- 10,000 counts, 4 digits display
- Zero and gain adjustable from the front panel
- Display adjustment by keys
- 2 independent alarm switches
- 4-20mA or 0-10V analog output
- Average value - Tare feature



Id-CC4 digital indicator supplies and provides strain gauges sensors conditioning with full bridge and wide range of impedance. It makes easier use of almost all sensors: strain, weight and, in some cases, pressure sensors. Zero and gain are programmable from the front panel in preset ranges by mini-switches located on the side.

Id-CC4 is delivered with 2 independent alarm switches on 2 relays 1T and 1 fully adjustable analog output (4-20 mA or 0-10 VDC). Keys located on the front panel behind the red filter ensure a quick and precise adjustment for the direct display in engineering units and for the alarms values. The **average value** feature can be easily activated to smoothen transients of the process value. An easy and user-friendly is available to configure following parameters: analog output adjustment, alarm relays statuses (**NO/NC (*)**), calculation features (minimum or maximum), choice of the display resolution (1-2-5-10), customer-tailored linearization table. Validation of the tare feature is done by pushing at the same time 2 front panel keys or by closing an external contact (remote reset). **CLA-option**, alarm keyboard on the front panel, can be used when the process often requests actions on alarms set-points or tare reset.

Id-CC4 is connected to the process by removable screw terminals 14 mm-LED display on 4 digits (10,000 counts) offers an accuracy of 0.1% of the range.

INPUTS and CONDITIONING

Complete bridge from 100 Ω to 5,000 Ω (100mA max.)
Possibility of conditioning 3x350 Ω parallel sensors with 10 VDC excitation. Excitation given to the bridge: 5 or 10VDC.
Gain and zero programmable by keys on the front panel to obtain engineering units direct display.
Zero accepts: -50 to +25% F.S.
Full scale selection by mini-dips on the side of the housing (200mV-30mV-20mV-10mV).

ALARMS SWITCHES

2 independent alarm switches, programmed from the front panel after removing the front filter or from the front panel (**CLA-option**). Adjustable switches on the whole display range (-1,999 to +9,999 counts). Accuracy : 1 count. Relays: -1A, 230 VAC, 1A, $\cos\phi$ 0.7.
2 statuses LED's on the front panel. Possibility to reverse the relay action. Programmable hysteresis on each setpoint

ENVIRONMENTAL

Operating temperature : from 0 to +60°C
Storage temperature : from -40 to +85°C

HOUSING

Noryl panel mount housing.
All connections by pull-out screw terminals
Dimensions : front panel 48 x 96 mm – Depth 133 mm - overall depth including terminals : 151mm
Front panel cut-out 43 x 92 mm screw clips mount.
Rated IP20 protection - Door option rated IP55.



The equipment bears the **CE** mark, in accordance with directives 89 336/CEE and 73/23/CEE - electromagnetic compatibility.

This system meets the following standards :
EN50081-2, EN50082-2 and EN 61010.

ACCURACY

Linearity $\pm 0,1$ % F.S. + 1 count
Thermal drift: max. 40ppm/°C
7 readings per second

POWER SUPPLY

Standard 230V 50Hz – Consumption 6W. On request
110V 50Hz – 48V 50Hz - 24V 50Hz. - Optional : 24VDC

DISPLAY

-1,999 to +9,999 counts, red LED
Over range display : \pm dEP
Decimal point programmable from the front panel.
Modulo display programmable (1-2-5-10)

ANALOG OUTPUT

Must be defined at order as current output (4-20mA or 0-20mA), quote SA3 or as voltage output (0-10 VDC) quote SA2. The analog output values low- and high-scale values are adjustable on the full range from -2,000 to +10,000 counts. Non isolated output.

Current output (SA3) :

Select 4-20mA or 0-20mA by program
Maximum voltage load on a 600 Ohm-shunt (15V)

Maximum current limited to 50 mA

Voltage output 0 to 10VDC (SA2) :

Maximum current limited to 10 mA
Accuracy : 0.1%, response time : 150 ms
Output load : < 75 Ω

PRESSURE / LOAD
DRUCK / KRAFT

PRESSION / FORCE

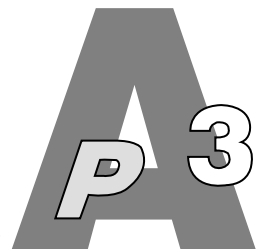

CONNECTIONS

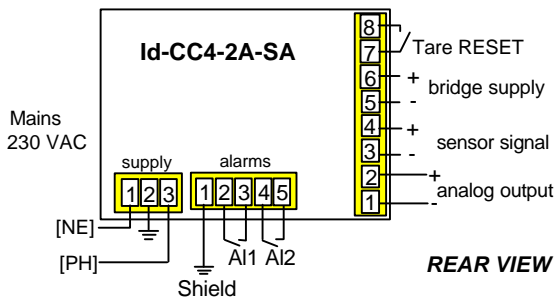

Set DIPs to select sensor supply, full scale and compensation range. A wrong choice may create over range or sensors resolution problems.

DISPLAY ADJUSTMENT and CONFIGURATION

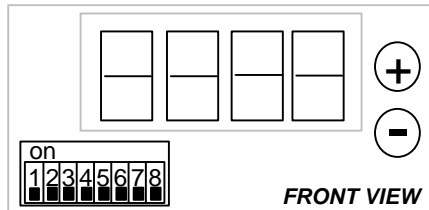

When the front filter is removed, the system is no longer protected from electrostatic discharges on the front panel (801-2). Proper precautions must be taken when programming, as the unit is not in its normal operating configuration

1. Display adjustment

Put switch 1 to the "ON" position. The display indicates the high scale value for 20mA. Press the "+" key to increase or the "-" key to decrease the value. When the desired value is reached, put switch 1 to "OFF" position.
Put switch 2 to the "ON" position. The display indicates the low scale display value (0 or 4mA). Press the "+" key to increase or the "-" key to decrease the value. When the desired value is reached, put switch 2 to "OFF" position.

2. Programming the decimal point

Put switch 3 to the "ON" position. Press the "+" key to move the decimal point. When the decimal point is in the desired position, put switch 3 to the "OFF" position.

3. Activating the average value

Put switch 4 to the "ON" position to activate the average value display. Put switch 4 to the "OFF" position to return to direct display.

4. Programming the alarm switches

Put switch 7 (alarm 1) to the "ON" position. The display then indicates the alarm switch value n°1. Press the "+" key to increase or the "-" key to decrease the value. When the alarm n°1 value is reached, put switch 7 to the "OFF" position.
Do the same way for alarm n°2 (with switch 8).

5. Access to internal menu

The menu allows to choose, by mean of DIPs 6 then 5 the output type, relays statuses, and the calculation features (if any : minimum-maximum value).

Program mode

When programming, the rightest decimal point blinks

SIDE DIP CONFIGURATION CHART

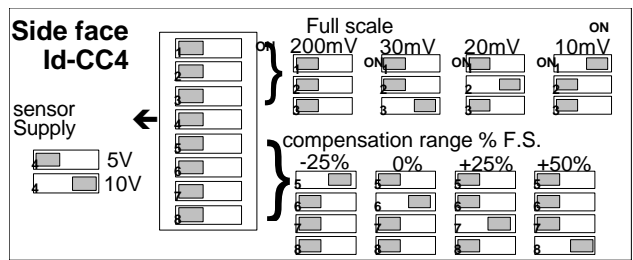

on = programming mode	blinking = programming
1 : Full scale display	5 and 6 :see manual
2 : Zero display	7 : Alarm 1
3 : Decimal point	8 : Alarm 2
4 : on = average value active	

id-CC4

To configure Id-CC4, take the front filter away to access to + and - keys and to front mini-DIP.

6. Tare RESET

Pushing + et - keys at the same time or closing external contact will start tare procedure => display « tArE ».
Pushing again + et - keys at the same time or closing external contact will start tare procedure => display - - -

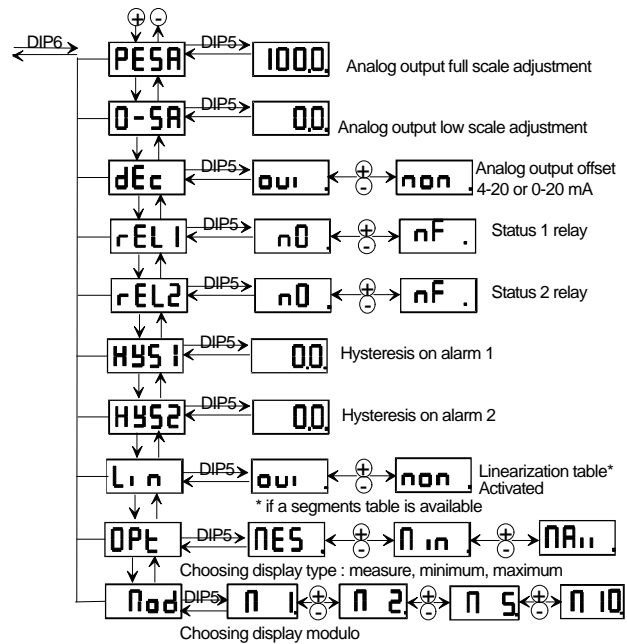

The linearization table is programmed in our factory as per your order or it can be done by the end-user with a PC interface and our dedicated program .

(*) NO/NC : Normally Open / Normally Closed

ADJUSTMENT

Connect to the input a signal corresponding to the high scale value. Put switches 1 and 3 in «ON» position. By means of «+» and «-», adjust the display. Pushing + and - keys at the same time will adjust it automatically. Put switches 1 and 3 «OFF» position.
Connect to the input a signal corresponding to the low scale value. Put switches 2 and 3 to «ON» position. By means of «+» and «-», adjust the display. Pushing + and - keys at the same time will adjust it automatically. Put switches 2 and 3 «OFF» position.

